

# BAC 55

01001070-xxx OLI-1



*\*Photo for illustrative purposes*

## External dimensions [L x l x h]

600 x 500 x 580 mm

## Internal dimensions\* [L x l x h]

415 x 315 x 410 mm

## Internal volume

53 L

## Empty weight

17 Kg

## Logistical specifications

Quarter ISO pallet 1000 x 1200 mm

*\* Average value for reference purposes*



Chilled



Frozen



Ambient

**olivo**  
cold logistics

1 bld des Mineurs 42230 Roche-la-Molière / [www.olivo.eu](http://www.olivo.eu)

## Insulated container standard specifications

### Box & Lid :

- **Monobloc wall** in UV-resistant food grade polyethylene ;
- Injected polyurethane foam ;
- **Monobloc silicone frame seal** ;
- **Sealing frontal toggle closure**, yellow zinc coating ;
- **Lid opening at 115°** ;
- 2 **side-handling handles** rotationally molded into the mass ;
- **Mass-produced boss** for stacking ;
- Maximum capacity of storable pellets :  $\approx$  40 kg.

## Accessory options

**Removable galvanized steel caster base**, rolling configuration according to the existing Olivo standard, sandwich polyamide wheel diameter 100 mm.

## Customization

**Signage** : heat-sealed adhesive – ready-to-print file provided by the client.

**Tracking** : temperature/GPS tracking solution.

**Logo molded into the mass.**

**Branding marking** : engraved aluminum plate 150 x 90 mm

## Cold source

### ADVICES

**Eutectic plate** : up to 2 eutectic plates TOP55 all temperature according to the existing Olivo standard.

**Dry ice drawer** : capacity of 6L, made of aluminum.

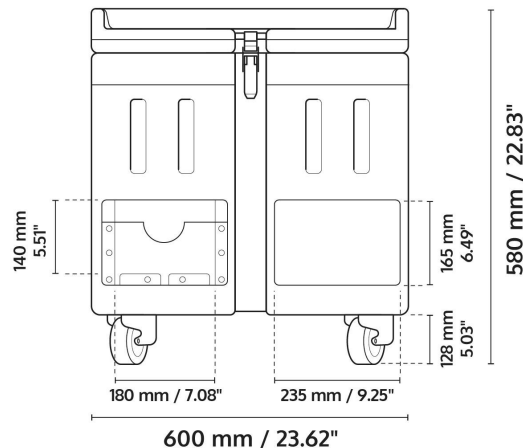

## Insulated container properties

Property	Value
Coef K.	0.39 W/m <sup>2</sup> .°C
ATP category	IR
Temperature resistance	-80°C/+70°C
Double wall thickness	$\approx$ 90 mm
Internal convection grooves	
Dynamic load capacity	480 Kg
Static load capacity	960 Kg
Construction	Double-walled, rotational-molded and grooved

For advice on best practices for use and thermal performance, contact the Olivo team / [contact@olivo.eu](mailto:contact@olivo.eu)



ATP

Update 26 /10/2023